



Black Oxide  
(Fit for normal conditions)



Nickel Plating  
(fit for dust-free conditions)

## FK Series

Order Coding	Model No.	Surface treatment	Applicable ballscrew accuracy grade	Bearing
FK05_C7	FK05	Black Oxide	C7	605
FK05_C7N		Electyless Nickel Plating	C7	605
FK06_C7	FK06	Black Oxide	C7	606
FK06_C5			C5	706A P0
FK06_C3			C3	706A P5
FK06_C7N		Electyless Nickel Plating	C7	606
FK06_C5N			C5	706A P0
FK06_C3N			C3	706A P5
FK08_C7			FK08	Black Oxide
FK08_C5	C5	708A P0		
FK08_C3	C3	708A P5		
FK08_C7N	Electyless Nickel Plating	C7		608
FK08_C5N		C5		708A P0
FK08_C3N		C3		708A P5
FK10_C7	FK10	Black Oxide	C7	7000A P0
FK10_C5			C5	7000A P0
FK10_C3			C3	7000A P5
FK10_C7N		Electyless Nickel Plating	C7	7000A P0
FK10_C5N			C5	7000A P0
FK10_C3N			C3	7000A P5
FK12_C7	FK12	Black Oxide	C7	7001A P0
FK12_C5			C5	7001A P0
FK12_C3			C3	7001A P5
FK12_C7N		Electyless Nickel Plating	C7	7001A P0
FK12_C5N			C5	7001A P0
FK12_C3N			C3	7001A P5
FK15_C7	FK15	Black Oxide	C7	7002A P0
FK15_C5			C5	7002A P0
FK15_C3			C3	7002A P5
FK15_C7N		Electyless Nickel Plating	C7	7002A P0
FK15_C5N			C5	7002A P0
FK15_C3N			C3	7002A P5

Order	Model	Surface	Applicable	Bearing
FK17_C7	FK17	Black Oxide	C7	7203A P0
FK17_C5			C5	7203A P0
FK17_C3			C3	7203A P5
FK17_C7N		Electyless Nickel Plating	C7	7203A P0
FK17_C5N			C5	7203A P0
FK17_C3N			C3	7203A P5
FK20_C7	FK20	Black Oxide	C7	7204A P0
FK20B_C7			C7	7204B P0
FK20_C5			C5	7204A P0
FK20B_C5			C5	7204B P0
FK20_C3		C3	7204A P5	
FK20_C7N		Electyless Nickel Plating	C7	7204A P0
FK20B_C7N			C7	7204B P0
FK20_C5N			C5	7204A P0
FK20B_C5N			C5	7204B P0
FK20_C3N			C3	7204A P5
FK25_C7	FK25		Black Oxide	C7
FK25B_C7		C7		7205B P0
FK25_C5		C5		7205A P0
FK25B_C5		C5		7205B P0
FK25_C3		C3		7205A P5
FK25_C7N		Electyless Nickel Plating	C7	7205A P0
FK25B_C7N			C7	7205B P0
FK25_C5N			C5	7205A P0
FK25B_C5N			C5	7205B P0
FK25_C3N			C3	7205A P5
FK30_C7	FK30	Black Oxide	C7	7206A P0
FK30B_C7			C7	7206B P0
FK30_C5			C5	7206A P0
FK30B_C5			C5	7206B P0
FK30_C3			C3	7206A P5
FK30_C7N		Electyless Nickel Plating	C7	7206A P0
FK30B_C7N			C7	7206B P0
FK30_C5N			C5	7206A P0
FK30B_C5N			C5	7206B P0
FK30_C3N			C3	7206A P5

Part No.	Part name	Qty
1	Block Body	1 pc
2	Bearing	1set
3	Binder Pate	1 pc
4	Distance Ring	2 pcs
5	Seal	2 pcs
6	Lock Nut	1 set
7	Hexagon Socket Set Screw	2 pcs

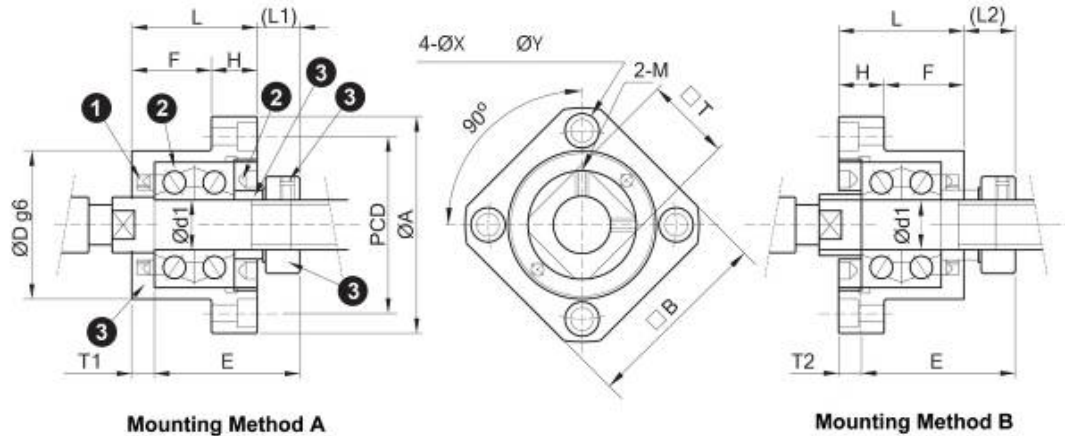

Unit: mm

Model No	d1	L	H	F	E	Dg6	A	PCD	B	Mounting A		Mounting B		X	Y	Z	M	T	
										L1	T1	L2	T2						
FK05	5	17	6	11	19	20	-0.007 -0.02	34	26	26	5.5	3.5	7	5	3.4	6.5	4	M3	11
FK06	6	20	7	13	22	22	-0.007 -0.02	36	28	28	5.5	3.5	8.5	6.5	3.4	6.5	4	M3	12
FK08	8	23	9	14	26	28	-0.007 -0.02	43	35	35	7	4	10	7	3.4	6.5	4	M3	14

Model No	d1	L	H	F	E	Dg6	A	PCD	B	Mounting A		Mounting B		X	Y	Z	M	T	
										L1	T1	L2	T2						
FK10	10	27	10	17	30	34	-0.009 -0.025	52	42	42	7.5	5	8.5	6	4.5	8	4	M3	16
FK12	12	27	10	17	30	36	-0.009 -0.025	54	44	44	7.5	5	8.5	6	4.5	8	4	M4	19
FK15	15	32	15	17	36	40	-0.009 -0.025	63	50	52	10	6	12	8	5.5	9.5	6	M4	22
FK17	17	45	22	23	47	50	-0.009 -0.025	77	62	61	11	9	14	12	6.6	11	10	M4	24
FK20	20	52	22	30	50	57	-0.010 -0.029	85	70	68	8	10	12	14	6.6	11	10	M4	30
FK25	25	57	27	30	60	63	-0.010 -0.029	98	80	79	13	10	20	17	9	15	13	M5	35
FK30	30	62	30	32	61	75	-0.010 -0.029	117	95	93	11	12	17	18	11	18	15	M6	40

FF Series

Order Coding	Model No.	Surface treatment	Applicable ballscrew accuracy grade	Bearing
FF06_C7	FF06	Black Oxide	C7	606ZZ
FF06_C3			C3	606ZZ
FF06_C7N		Electyless	C7	606VV
FF06_C3N		Nickel Plating	C3	606VV
FF10_C7	FF10	Black Oxide	C7	608ZZ
FF10_C3			C3	608ZZ
FF10_C7N		Electyless	C7	608DD
FF10_C3N		Nickel Plating	C3	608DD
FF12_C7	FF12	Black Oxide	C7	6000ZZ
FF12_C3			C3	6000ZZ
FF12_C7N		Electyless	C7	6000DDU
FF12_C3N		Nickel Plating	C3	6000DDU
FF15_C7	FF15	Black Oxide	C7	6002ZZ
FF15_C3			C3	6002ZZ
FF15_C7N		Electyless	C7	6002DDU
FF15_C3N		Nickel Plating	C3	6002DDU
FF17_C7	FF17	Black Oxide	C7	6203ZZ
FF17_C3			C3	6203ZZ
FF17_C7N		Electyless	C7	6203DDU
FF17_C3N		Nickel Plating	C3	6203DDU
FF20_C7	FF20	Black Oxide	C7	6204ZZ
FF20_C3			C3	6204ZZ
FF20_C7N		Electyless	C7	6204DDU
FF20_C3N		Nickel Plating	C3	6204DDU
FF25_C7	FF25	Black Oxide	C7	6205ZZ
FF25_C3			C3	6205ZZ
FF25_C7N		Electyless	C7	6205DDU
FF25_C3N		Nickel Plating	C3	6205DDU
FF30_C7	FF30	Black Oxide	C7	6206ZZ
FF30_C3			C3	6206ZZ
FF30_C7N		Electyless	C7	6206DDU
FF30_C3N		Nickel Plating	C3	6206DDU



Black Oxide  
(Fit for normal conditions)



Nickel Plating  
(fit for dust-free conditions)

1. It is used double pressed steel cages for Black Oxide type support units.
2. It is used double plastic cages for Electroless Nickel Plating type support units.
3. All of bearings Use Japan's brand bearings.

Part No.	Part name	Qty
1	Block	1 pc
2	Bearing	1 Pair
3	C-Rings	1 pc

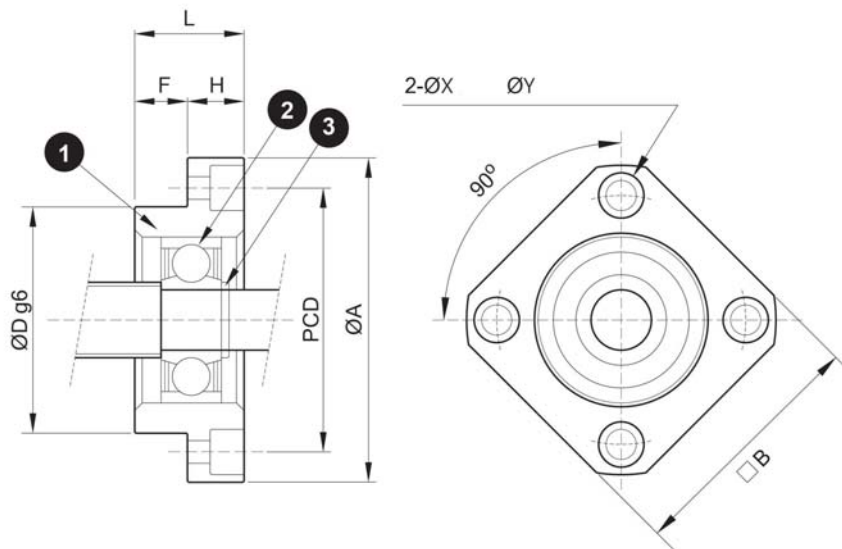

Unit: mm

Model No	d1	L	H	F	Dg6		A	PCD	B	X	Y	Z	Bearing	C-ring
FF06	6	10	6	4	22	-0.007 -0.02	36	28	28	3.4	6.5	4	606ZZ	S 06
FF10	8	12	7	5	28	-0.007 -0.02	43	35	35	3.4	6.5	4	608ZZ	S 08
FF12	10	15	7	8	34	-0.009 -0.025	52	42	42	4.5	8	4	6000ZZ	S 10
FF15	15	17	9	8	40	-0.009 -0.025	63	50	52	5.5	9.5	5.5	6002ZZ	S 15
FF17	17	20	11	9	50	-0.009 -0.025	77	62	61	6.6	11	6.5	6203ZZ	S 17
FF20	20	20	11	9	57	-0.010 -0.029	85	70	68	6.6	11	6.5	6004ZZ	S 20
FF25	25	24	14	10	63	-0.010 -0.029	98	80	79	9	14	8.5	6205ZZ	S 25
FF30	30	27	18	9	75	-0.010 -0.029	117	95	93	11	17.5	11	6206ZZ	S 30