

ER Series Explosion-Proof Rotary Motor and Gearmotor

For hazardous duty environments with constant exposure to flammable gasses or vapors* Exlar's ER Series rotary explosion-proof motors and gearmotors provide an excellent solution. Exlar's motors utilizing T-LAM™ technology, an innovative segmented winding, have been designed for efficiency, power and durability and provide a very high torque-to-size ratio when compared to other suppliers' motors.

The gearmotor comprises a brushless permanent magnet motor optimized for use with an integral planetary gear set. Through the uniform load sharing of several gears acting in concert, planetary gear heads are a very compact, reliable solution providing high torque, low backlash and low maintenance.

The ER Series motors are compatible with nearly any manufacturers' resolver-based amplifier.

**ER Series motors are rated for Class I, div 1, Groups B, C and D. "Class I" means that flammable gasses or vapors may be present in the air in quantities sufficient to produce explosive or ignitable mixtures. "Division 1" means that hazardous concentrations in the air may exist continuously, intermittently, or periodically under normal operating conditions. "Group B" allows for atmospheres containing hydrogen, or gasses (or vapors) of equivalent hazard, such as manufactured gas. "Group C" allows for atmospheres containing ethyl-ether vapors, ethylene or cyclo propane. "Group D" allows for atmospheres containing gasoline, hexane, naphtha, benzene, butane, alcohol, acetone, benzol, lacquer solvent vapors or natural gas. ER Series motors are not rated for operation in atmospheres containing acetylene.*

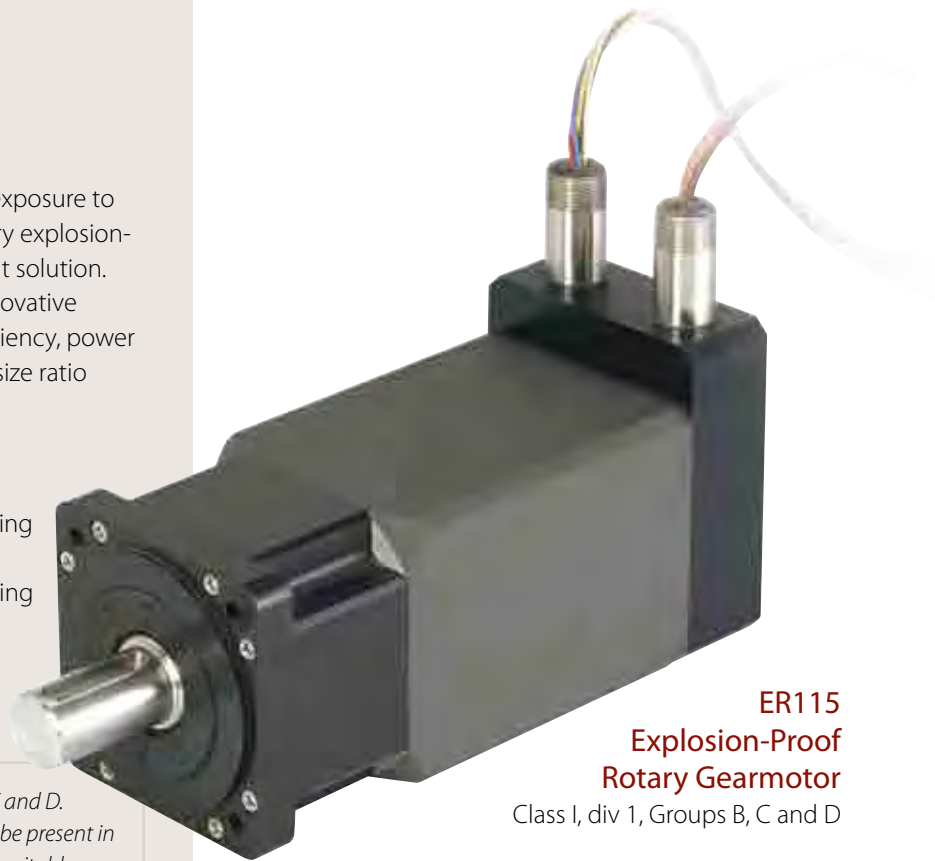

**ER115
Explosion-Proof
Rotary Gearmotor**

Class I, div 1, Groups B, C and D

Features

T-LAM technology yielding 35% increase in continuous motor torque over traditional windings

Resolver feedback

8 pole motors

Rod end options

1, 2, or 3 stack motor availability compatible with nearly any resolver based servo amplifier

Several mounting configurations

Potted NPT connectors

Windings from 24 VDC to 460 VAC rms

Class 180H insulation system

Typical Applications for ER Series explosion-proof motors are Well-suited to many applications such as:

- Turbine fuel flow
- Printing presses
- Engine test stands
- Fuel distribution systems
- Chemical process plants
- Shipbound fuel management
- Paint booths

ER Speed/Torque Curves

- - - - - Peak Torque
————— Continuous Torque
 Torque Rated at 80°C

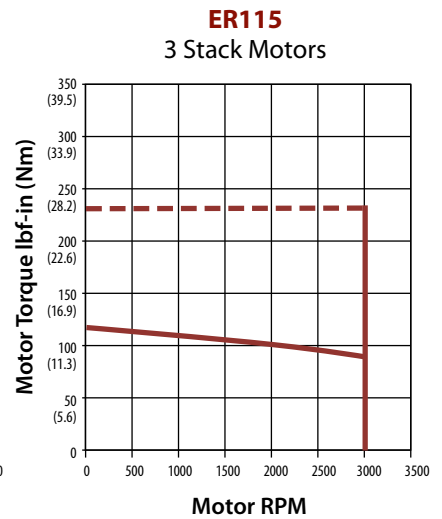
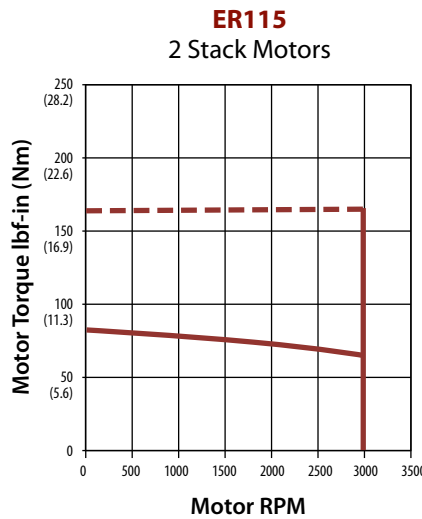
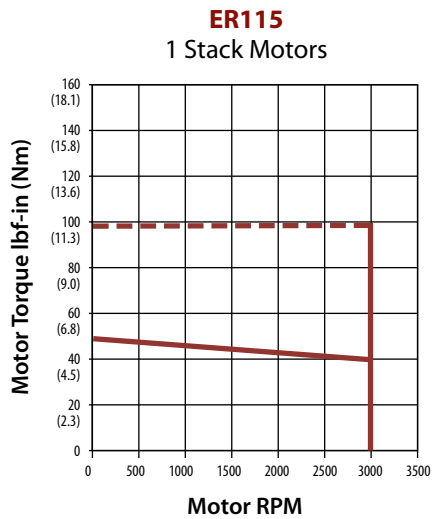

Hazardous Location ER Series Linear Actuators

ER115 Electrical/Mechanical Specifications

Sinusoidal Commutation Data		1A8	1B8	118	138	158	168	2A8	2B8	238	258	268	338	358	368
Continuous Motor Torque**	lbf-in (Nm)	49.7 (5.61)	49.7 (5.61)	50.5 (5.70)	50.5 (5.70)	50.6 (5.72)	50.5 (5.70)	83.3 (9.41)	83.3 (9.41)	84.0 (9.49)	82.5 (9.32)	84.0 (9.49)	117.3 (13.25)	117.6 (13.29)	120.4 (13.60)
Peak Motor Torque	lbf-in (Nm)	99.3 (11.22)	99.3 (11.22)	101.0 (11.41)	101.0 (11.41)	101.2 (11.44)	100.9 (11.40)	166.6 (18.82)	166.6 (18.82)	168.0 (18.98)	165.0 (18.64)	168.0 (18.98)	234.6 (26.50)	235.3 (26.58)	240.8 (27.21)
Torque Constant (Kt)**	lbf-in/A	5.3	5.3	4.3	8.7	15.7	17.4	5.3	5.3	8.7	15.9	17.4	8.5	15.9	17.6
(+/- 10% @ 80°C)	(Nm/A)	0.60	0.6	0.5	1.0	1.8	2.0	0.6	0.6	1.0	1.8	2.0	1.0	1.8	2.0
Continuous Current Rating	A	10.5	10.5	13.0	6.5	3.6	3.2	17.6	17.6	10.8	5.8	5.4	15.4	8.3	7.7
Peak Current Rating	A	21.0	21.0	26.0	13.0	7.2	6.5	35.2	35.2	21.6	11.6	10.8	30.8	16.6	15.3
TRAPEZOIDAL COMMUTATION DATA															
Continuous Motor Torque**	lbf-in (Nm)	47.4 (5.36)	47.4 (5.36)	48.2 (5.45)	48.2 (5.45)	48.3 (5.46)	48.2 (5.45)	79.5 (8.99)	79.5 (8.99)	80.2 (9.06)	78.8 (8.90)	80.2 (9.06)	112.0 (12.66)	112.3 (12.69)	115.0 (12.99)
Peak Motor Torque	lbf-in (Nm)	94.8 (10.71)	94.8 (10.7)	96.4 (10.9)	96.4 (10.9)	96.7 (10.9)	96.4 (10.9)	159.1 (18.0)	159.1 (18.0)	160.4 (18.1)	157.6 (17.8)	160.4 (18.1)	224.0 (25.3)	224.7 (25.4)	230.0 (26.0)
Torque Constant (Kt) (+/- 10% @ 80°C)	lbf-in/A (Nm/A)	4.12 (0.47)	4.12 (0.47)	3.39 (0.38)	6.78 (0.77)	12.22 (1.38)	13.55 (1.53)	4.12 (0.47)	4.12 (0.47)	6.78 (0.77)	12.37 (1.40)	13.55 (1.53)	6.63 (0.75)	12.37 (1.40)	13.70 (1.55)
Continuous Current Rating	A	12.85	12.85	15.90	7.95	4.42	3.97	21.55	21.55	13.23	7.12	6.61	18.88	10.14	9.38
Peak Current Rating	A	25.69	25.69	31.81	15.90	8.84	7.95	43.10	43.10	26.46	14.23	13.23	37.76	20.29	18.76
MOTOR DATA															
Voltage Constant (Ke)**	Vpk/Krpm	36.1	36.1	29.7	59.4	107.1	118.7	36.1	36.1	59.4	108.4	118.7	58.1	108.4	120.0
(+/- 10% @ 80°C)	Vrms/Krpm	51.1	51.1	42.0	83.9	151.4	167.9	53.1	51.1	83.9	153.3	167.9	82.1	153.3	169.7
Pole Configuration		8	8	8	8	8	8	8	8	8	8	8	8	8	8
Resistance (L-L)(+/- 5% @ 25°C)	Ohms	0.31	0.31	0.20	0.80	2.60	3.21	0.13	0.13	0.34	1.17	1.35	0.20	0.69	0.81
Inductance (L-L)(+/- 15%)	mH	4.8	4.8	3.3	13.0	42.4	52.1	2.3	2.3	6.3	21.1	25.3	4.0	13.9	17.1
Armature Inertia	lb-in-sec ² (Kg-cm ²)	0.00555 (6.27)						0.00833 (9.42)				0.01112 (12.56)			
Mechanical Time Constant (tm)	ms	0.85	0.85	0.82	0.82	0.82	0.82	0.53	0.53	0.52	0.54	0.52	0.43	0.42	0.40
Electrical Time Constant (te)	ms	15.73	15.73	16.26	16.26	16.34	16.25	18.41	18.41	18.72	18.06	18.72	20.08	20.19	21.16
Damping Constant	lbf-in/krpm (N-m/krpm)	0.21 (0.024)	0.21 (0.024)	0.21 (0.024)	0.21 (0.024)	0.21 (0.024)	0.21 (0.024)	0.35 (0.040)	0.35 (0.040)	0.35 (0.040)	0.35 (0.040)	0.35 (0.045)	0.40 (0.045)	0.40 (0.045)	0.40 (0.045)
Friction Torque	lbf-in (Nm)	0.56 (0.063)	0.56 (0.063)	0.56 (0.063)	0.56 (0.063)	0.56 (0.063)	0.56 (0.063)	1.00 (0.113)	1.00 (0.113)	1.00 (0.113)	1.00 (0.113)	1.00 (0.136)	1.20 (0.136)	1.20 (0.136)	1.20 (0.136)
Bus Voltage	Vrms	24VDC	48VDC	115	230	400	460	24VDC	48VDC	230	400	460	230	400	460
Speed @ Bus Voltage	rpm	300	750	3000	3000	3000	3000	300	750	3000	3000	3000	3000	3000	3000
Insulation Class		180 (H)													
Insulation System Volt Rating	Vrms	460													
Class Temperature	°C	T4 = 135° T3A = 180°													
Environmental Rating		IP65													

ER115 Gearmotor Data

	1 Stack Motor	2 Stack Motor	3 Stack Motor
ER115 Armature Inertia* lbf-in-sec ² (Kg-cm ²)	0.00344 (3.89)	0.00441 (4.99)	0.00538 (6.08)

For amplifiers using peak sinusoidal ratings, multiply RMS sinusoidal Kt by .707 and current by 1.414.

GEARING REFLECTED INERTIA	SINGLE REDUCTION			DOUBLE REDUCTION		
	Gear Stages	lbf-in-sec ²	(Kg-cm ²)	Gear Stages	lbf-in-sec ²	(Kg-cm ²)
	4:1	0.0000132	(0.0149)	16:1	0.0000121	(0.0137)
	5:1	0.0000087	(0.00984)	20:1, 25:1	0.0000080	(0.00906)
	10:1	0.0000023	(0.00261)	40:1, 50:1, 100:1	0.0000021	(0.00242)
Backlash at 1% rated torque:	10 Arc minutes Efficiency: Single reduction 91%			13 Arc minutes Double Reduction: 86%		

* Add armature inertia to gearing inertia for total ER system inertia

** For T3A Temperature Class multiply Kt and Ke ratings by 0.83; continuous current by 1.245; continuous torque by 1.095.

ER115 Series Gearmotor General Performance Specifications

Two torque ratings for the ER Series Gearmotors are given in the table below. The left hand columns give the maximum (peak) allowable output torque for the indicated ratios of each size ER Series Gearmotor. This IS NOT the rated output torque of the motor multiplied by the ratio of the reducer.

It is possible to select a configuration of the motor selection and gear ratio such that the rated motor torque, multiplied by

the gear ratio exceeds these ratings. It is the responsibility of the user to ensure that the settings of the system, including the amplifier, do not allow these values to be exceeded.

The right hand columns give the output torque at the indicated speed which will result in 10,000 hour (L10). The setup of the system, including the amplifier, will determine the actual output torque and speed.

Output Torque Ratings – Mechanical

ER115 Ratio	Maximum Allowable Output Torque ibf. in (Nm)	Output Torque @ Speed for 10,000 Hour Life – ibf. in (Nm)		
		1000 RPM	3000 RPM	5000 RPM
4:1	4696 (530.4)	1392 (157.3)	1132 (127.9)	1000 (112.9)
5:1	4066 (459.4)	1445 (163.3)	1175 (132.8)	1040 (117.5)
10:1	2545 (287.5)	1660 (187.6)	1350 (152.6)	1200 (135.6)
16:1	4696 (530.4)	2112 (238.6)	1714 (193.0)	1518 (171.0)
20:1	4696 (530.4)	2240 (253.1)	1840 (207.9)	1620 (183.0)
25:1	4066 (459.4)	2350 (265.5)	1900 (214.7)	1675 (189.2)
40:1	4696 (530.4)	2800 (316.4)	2240 (253.1)	2000 (225.9)
50:1	4066 (459.4)	2900 (327.7)	2350 (265.5)	2100 (237.3)
100:1	2545 (287.5)	2500 (282.5)	2500 (282.5)	2400 (271.2)

Radial Load and Bearing Life

RPM	ER115 lbf (N)
50	939 (4177)
100	745 (3314)
250	549 (2442)
500	435 (1935)
1000	346 (1539)

Side load ratings shown below are for 10,000 hour bearing life at 25mm from motor face at given rpm.

Visit www.exlar.com for full details on radial load and bearing life.

Motor and Gearmotor Weight

ER115	Motor lb (kg)	1 Stage lb (kg)	2 Stage lb (kg)
1 Stack	14.2 (6.4)	28 (12.7)	34 (15.4)
2 Stack	22.0 (10)	35.8 (16.2)	41.8 (18.9)
3 Stack	29.8 (13.5)	43.6 (19.8)	49.6 (22.5)

Hazardous Location ER Series Linear Actuators

ER115

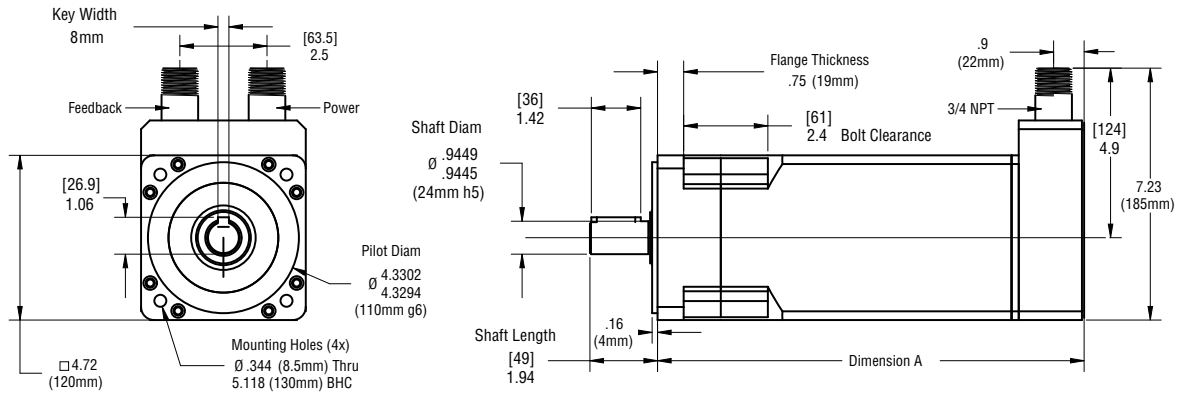

Gear Reduction		Dimension "A"
Stages	Stacks	Length in (mm)
0	1	8.3 (210)
0	2	10.3 (261)
0	3	12.3 (311)

ER115 with Gear Reduction Option

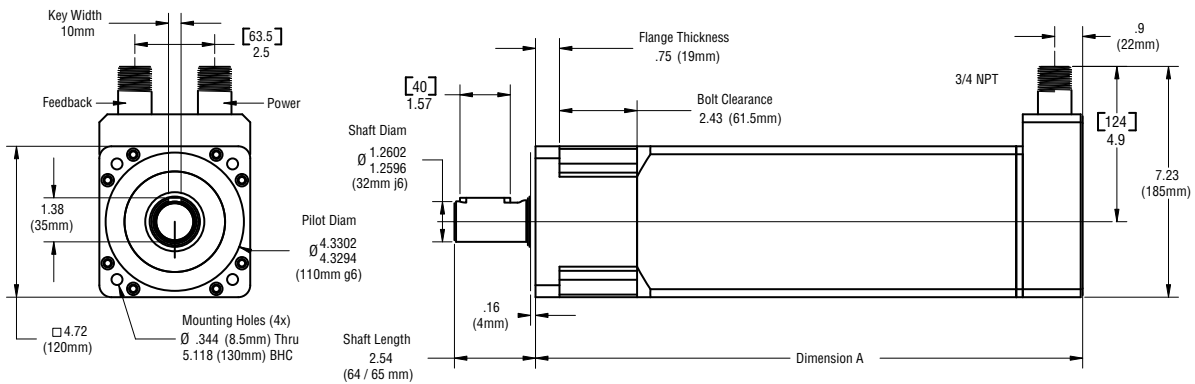

Gear Reduction		Dimension "A"
Stages	Stacks	Length in (mm)
1	1	11.6 (293)
	2	13.6 (344)
	3	15.6 (395)

Gear Reduction		Dimension "A"
Stages	Stacks	Length in (mm)
2	1	13.2 (334)
	2	15.2 (385)
	3	17.2 (436)

Drawings subject to change. Consult Exlar for certified drawings.

ER = Model Series

ER = Series

AAA = Frame Size

115 = 115 mm

BBB = Gear Reduction Ratio

(Optional - blank for motor)

- 004 = 4:1 Single stage reduction
- 005 = 5:1 Single stage reduction
- 010 = 10:1 Single stage reduction
- 016 = 16:1 Two stage reduction
- 020 = 20:1 Two stage reduction
- 025 = 25:1 Two stage reduction
- 040 = 40:1 Two stage reduction
- 050 = 50:1 Two stage reduction
- 100 = 100:1 Two stage reduction

CC = Shaft Type

- K = Keyed
- R = Smooth /Round
- X = Special shaft

D = Connection Options

- N## = Potted NPT with flying leads
- ## = length of flying leads in feet (not to exceed 99') consult Exlar applications engineering if longer lengths are needed.

F = Brake Options

- S = Standard no brake

GGG = Feedback Type

(Also specify the Amplifier/Drive Model being used when ordering)

- Standard Resolver – Size 15 1024 line (2048 cts) per rev., two pole resolver
- XX1 = Custom Feedback – Wiring and feedback device information must be provided and new feedback callout will be created – Please consult application engineering – Resolver only
- AB6 = Allen-Bradley/Rockwell – Standard Resolver
- AM3 = Advanced Motion Control – Standard Resolver
- AP1 = API Controls – Standard Resolver
- BD2 = Baldor – Standard Resolver
- BM2 = Baumuller – Standard Resolver
- BR1 = B&R Automation – Standard Resolver
- CO2 = Copley Controls – Standard Resolver
- CT5 = Standard Resolver
- DT2 = Delta Tau Data Systems – Standard Resolver
- EL1 = Elmo Motion Control – Standard Resolver
- EX4 = Exlar – Standard Resolver
- IF1 = Infranor – Standard Resolver
- IN6 = Indramat/Bosch-Rexroth – Standard Resolver
- JT1 = Jetter Technologies – Standard Resolver
- KM5 = Kollmorgen/Danaher – Standard Resolver
- LZ5 = Lenze/AC Tech – Standard Resolver
- MD1 = Modicon – Standard Resolver
- MG1 = Moog – Standard Resolver
- MN4 = Momentum – Standard Resolver
- MX1 = Metronix – Standard Resolver
- OR1 = Ormec – Standard Resolver
- PC7 = Parker – Standard Resolver – European only
- PC0 = Parker – Standard Resolver – US only
- PS3 = Pacific – Scientific Standard Resolver
- SM2 = Siemens – Standard Resolver
- SW1 = SEW/Eurodrive – Standard Resolver
- WD1 = Whedco/Fanuc – Standard Resolver

HHH = Motor Stator, All 8 Pole

- 1A8 = 1 stack, 24 Vrms
- 1B8 = 1 stack, 48 Vrms
- 118 = 1 stack, 115 Vrms
- 138 = 1 stack, 230 Vrms
- 158 = 1 stack, 400 Vrms
- 168 = 1 stack, 460 Vrms
- 2A8 = 2 stack, 24 Vrms
- 2B8 = 2 stack, 48 Vrms
- 238 = 2 stack, 230 Vrms
- 258 = 2 stack, 400 Vrms
- 268 = 2 stack, 460 Vrms
- 338 = 3 stack, 230 Vrms
- 358 = 3 stack, 400 Vrms
- 368 = 3 stack, 460 Vrms

II = Speed Designations

01-99 Two digit number. Rated speed in rpm X 100

JJJ = Hazardous Location Temperature Rating

- T3A = 180°C (Samarium Cobolt magnets)
- T4 = 135°C (Neodymium-Iron-Boron magnets)

XX = Optional Speed & Mechanical Designations

XL = Special lubrication

= Part Number Designator for Specials

= Optional 5 digit assigned part number to designate unique model number for specials